

3D CLASSIC DECKING BOARD

Composition:	<ul style="list-style-type: none"> • 60% – wood flour • 35% – high-density polyethylene (HDPE) • 5% – anti-UV additives, stabilizers, colourants
Dimensions:	<ul style="list-style-type: none"> • thickness – 21 mm ($\pm 1,5$ mm) • width – 145 mm ($\pm 1,5$ mm) • length – 3-4 m (± 5 mm) • weight – 3,0 kg/rm (-5%/+10%)
Properties:	<ul style="list-style-type: none"> • use in temperatures -30 °C/+60 °C • low water absorption <0.7% (frost-resistant) • high resistance to UV • high resistance to cracking (excluding cracks caused by shock load) • high resistance to rotting and decay resulting from the direct action of fungi and bacteria • high resistance to damage caused by the direct impact of insects • reinforced internal structure, rectangular chambers in cross-section
Usage:	<ul style="list-style-type: none"> • terraces • stairs • alleys • balconies • fences • swimming pool areas

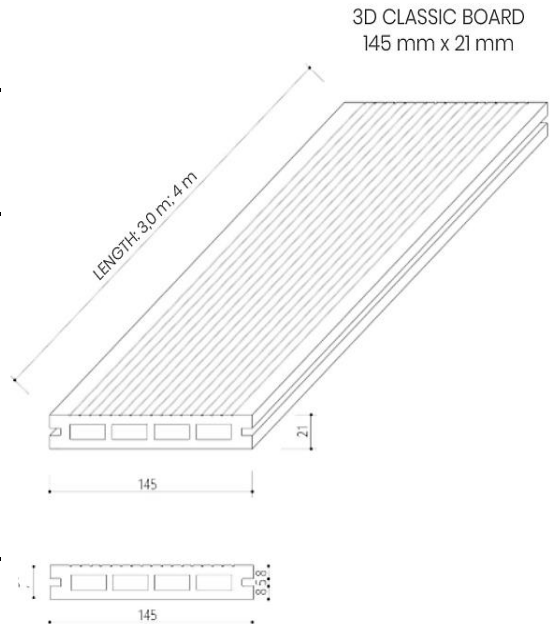

Available colours:



EcoTravers decking boards should not be installed in closed, damp and unventilated rooms, as well as in places with rapid and significant temperature changes (e.g. sauna).

Before installation read the instructions on www.liderwood.com.

During the first exploitation period the composite boards age under the influence of external conditions. The color stabilizes after a few months, reaching its final saturation. EcoTravers composite products may deviate from the available descriptions and samples in terms of natural color or structure differences. The boards may be subject to slight deformation (~1.5%).

Available documents:

- Guarantee certificate
- Terms of use
- Installation instructions