

## 3D Composite Decking Tiles

3D COMPOSITE DECKING TILE  
300 mm x 300 mm x 25 mm

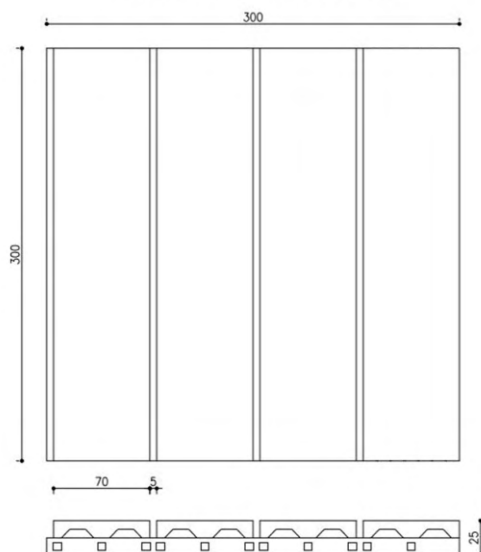

<b>Composition:</b>	<p>Composite board</p> <ul style="list-style-type: none"> <li>• 60% – wood flour</li> <li>• 35% – high-density polyethylene (HDPE)</li> <li>• 5% – anti-UV additives, stabilizers, colourants</li> </ul> <p>Base</p> <ul style="list-style-type: none"> <li>• Polypropylene</li> </ul>
<b>Dimensions:</b>	<p>3D Composite decking tile</p> <ul style="list-style-type: none"> <li>• thickness – 25 mm (<math>\pm 0,5</math> mm)</li> <li>• length/width – 300 mm (<math>\pm 1,0</math> mm)</li> </ul> <p>Decking tile left/right corner</p> <ul style="list-style-type: none"> <li>• thickness – 25 mm (<math>\pm 0,5</math> mm)</li> <li>• length – 380 mm (<math>\pm 1,0</math> mm)</li> <li>• width – 80 mm (<math>\pm 1,0</math> mm)</li> </ul> <p>Premium decking tile edge</p> <ul style="list-style-type: none"> <li>• thickness – 25 mm (<math>\pm 0,5</math> mm)</li> <li>• length – 300 mm (<math>\pm 1,0</math> mm)</li> <li>• width – 80 mm (<math>\pm 1,0</math> mm)</li> </ul>
<b>Properties:</b>	<ul style="list-style-type: none"> <li>• use in temperatures <math>-30^{\circ}\text{C}/+60^{\circ}\text{C}</math></li> <li>• low water absorption <math>&lt;0,5\%</math> (frost-resistant)</li> <li>• high resistance to UV</li> <li>• high resistance to cracking (excluding cracks caused by shock load)</li> <li>• high resistance to rotting and decay resulting from the direct action of fungi and bacteria</li> <li>• high resistance to damage caused by the direct impact of insects</li> </ul>
<b>Usage:</b>	<ul style="list-style-type: none"> <li>• terraces</li> <li>• alleys</li> <li>• balconies</li> </ul>

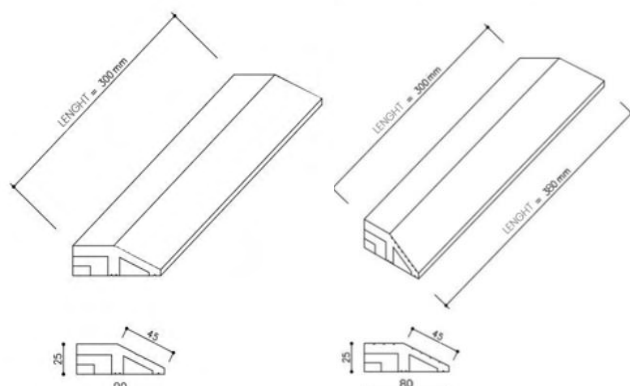

**Available colours:**

**Honey Teak**



**Brown**



EcoTravers decking tiles should not be installed in closed, damp and unventilated rooms, as well as in places with rapid and significant temperature changes (e.g. sauna). The substrate should be flat, hardened and with a slope of 2%.

**Before installation read the instructions on [www.liderwood.com](http://www.liderwood.com).**

During the first exploitation period the composite decking tiles age under the influence of external conditions. The color stabilizes after a few months, reaching its final saturation. EcoTravers composite products may deviate from the available descriptions and samples in terms of natural color or structure differences. The boards may be subject to slight deformation ( $\sim 1.5\%$ ).

**Available documents:**

- Guarantee certificate
- Terms of use